



COMMANDER VHF-144 2 METER LINEAR AMPLIFIER

Owner's Manual



PALSTAR, INC.
Command Technologies Division
9676 N. Looney Road
Piqua, Ohio 45356
U.S.A.

Customer Service and Sales Telephone: 800-773-7931

Fax: 937-773-8003

E-mail: info@palstar.com

Table of Contents

Introduction	3
Inside View	4
Specifications	5
Unpacking Instructions	6
Safety Warnings and Precautions	6
Front & Rear Layout	7
Installation Preparation	8
Operating Procedure	9
Operating Hints	10
Typical Operating Conditions Table	10
Warranty, Service, and Returns	11
HV Power Supply Schematic	12
AC Mains & Step-Start Schematic	13
Control & Metering Board Schematic	14
RF Deck Schematic	15
T/R Relay Board Schematic	16
Voltage Doubler Power Supply Schematic	17
<u>PHOTO APPENDIX:</u>	
RF Deck	18
Dual Meters	19
Meter Board	20
Step-Start Board	21
Power Supply	22

INTRODUCTION

The Commander VHF-144 is a grounded grid AB2 linear power amplifier that operates on the Amateur 2 meter band (144 to 148 MHz).

A single CPI/Eimac 3CPX800A7 pulse-rated external anode triode with forced air cooling and modern stripline circuitry ensures efficient and conservative operation.

The 6:1 ratio vernier reduction drives on all tuning controls allow smooth and easy tune up, while the front panel input tuning control allows a higher input circuit "Q" for excellent linearity which presents a low input VSWR to the exciter across the entire 2 meter band.

An automatic delay circuit, for proper cathode conditioning before RF drive is applied, which extends tube life. This is preformed by a microprocessor, which also controls a step/start dual relay system for a safe and effective control AC input startup.

The Commander VHF-144 features a full compliment of control and metering functions for easy on-air operation. By using 2 cross-needle metering, it allows viewing of all functions simultaneously.

This processor also features a gird-trip at 70ma of grid current. When activated by overdriving the amplifier, the green LED will flash at a high rate.

Reset is provided by switching the operate/standby switch from operate to standby and back again.

A dual primary power transformer allows 117VAC, 200VAC or 234VAC operation.

Commander VHF-144 Inside Layout

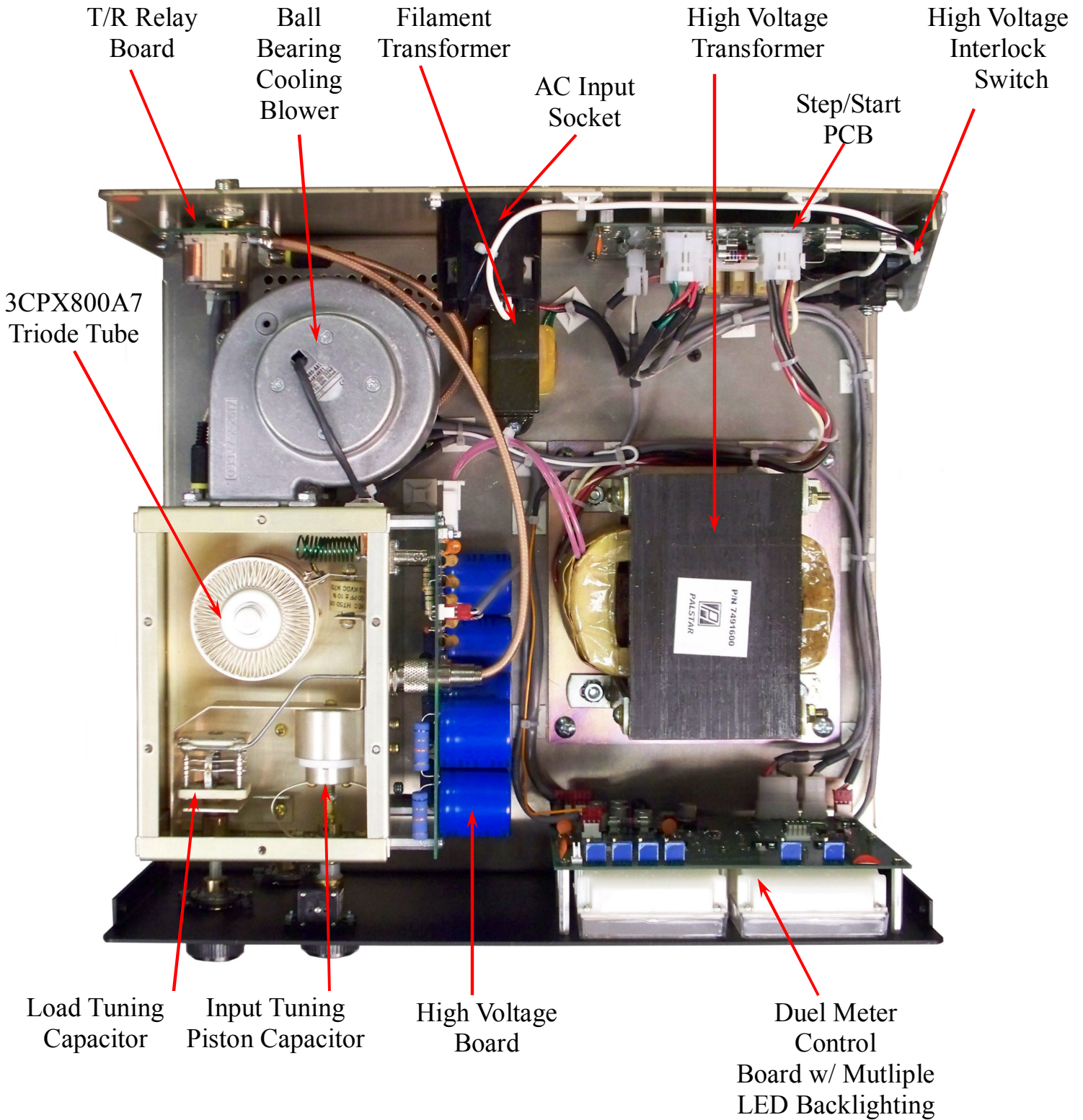

Specifications

Commander VHF-144

2 Meter VHF Linear Power Amplifier

- Frequency Range: 144 to 148 MHz.
- Modes: USB, LSB, RTTY, FM, CW.
- Power Requirements: 200/234VAC 50/60 Hz.
- RF Drive Power: 10 to 15 Watts nominal; 30 Watts maximum, for full 1 KW (CW) output.
- Grid-trip Current: 70ma
- RF Output: 1 Kw pep (USB, LSB); 650 Watts cw FM, 450 Watts.
- Input Impedance: 50 Ohms unbalanced, front panel adjustable.
- Output Impedance: 50 Ohms nominal.
- Antenna Load (VSWR): 2:1 maximum.
- Harmonic Suppression: better than 60db down at rated output.
- Intermodulation Distortion: better than 35 dB down at rated output.
- Weight (with transformer): 43 lbs. (19.5 Kg).
- Cabinet Size: 14.5" x 14.5" x 6" (36.8cm x 36.8 cm x 15.2 cm).
- Tube Compliment: one 3CPX800A7 ceramic pulse-rated metal triode.
- Cooling: pressurized chassis forced air, with a die cast bearing blower.
- Antenna Relay: DPDT; .1 dB insertion loss.
- Fuse: Type SFE; 234VAC and 200VAC operation: 15 Amp.
- Female AC plug on a 6' 12ga 3-wire line cord included

UNPACKING INSTRUCTIONS

Carefully remove your Commander VHF-144 from its shipping carton making sure there is no damage evident from shipping. If there is any damage, notify the delivering shipper immediately, fully describing the damage.

Do not destroy the packing material, since it may be reusable later, should you require factory service, or need to transport the Amplifier for any other reason.

CAUTIONS:

- DO NOT attempt any type of service or repair on this amplifier without first removing the AC power and allowing **AT LEAST 10 MINUTES FOR THE HIGH VOLTAGE CAPACITORS TO BLEED OFF !**
- DO NOT operate this amplifier with the top or bottom covers removed. DO NOT operate this amplifier with the internal RF tube compartment covers removed.
- **CONTACT WITH VOLTAGES IN THE CABINET CAN BE FATAL ! CLOSE QUARTER EXPOSURE TO UNSHIELDED RF AT THESE POWER LEVELS AND FREQUENCY IS HAZARDOUS TO YOUR HEALTH !**
- Never attempt operation without first connecting an appropriate antenna (2:1 VSWR Max) or a 50 ohm dummy load with sufficient rating or **SERIOUS DAMAGE TO THE AMPLIFIER MAY RESULT.**
- Never operate the amplifier with more drive than required to produce the rated output for the operating mode used (**Max 25-30 Watt**).
- **Do not place the Commander VHF-144 in repeater operation.** This amplifier is not designed for unattended service. Extensive modification would be required for this type of service.
- Never operate any amplifier using an extension cord.

**IF ANY SITUATION YOU ARE NOT SURE ABOUT OCCURS,
PLEASE CONTACT MANUFACTURER FOR ASSISTANCE.**

!! WARNING !!

CONTACT WITH VOLTAGES IN THIS AMPLIFIER CAN BE

!!! FATAL!!!

Front Panel Layout

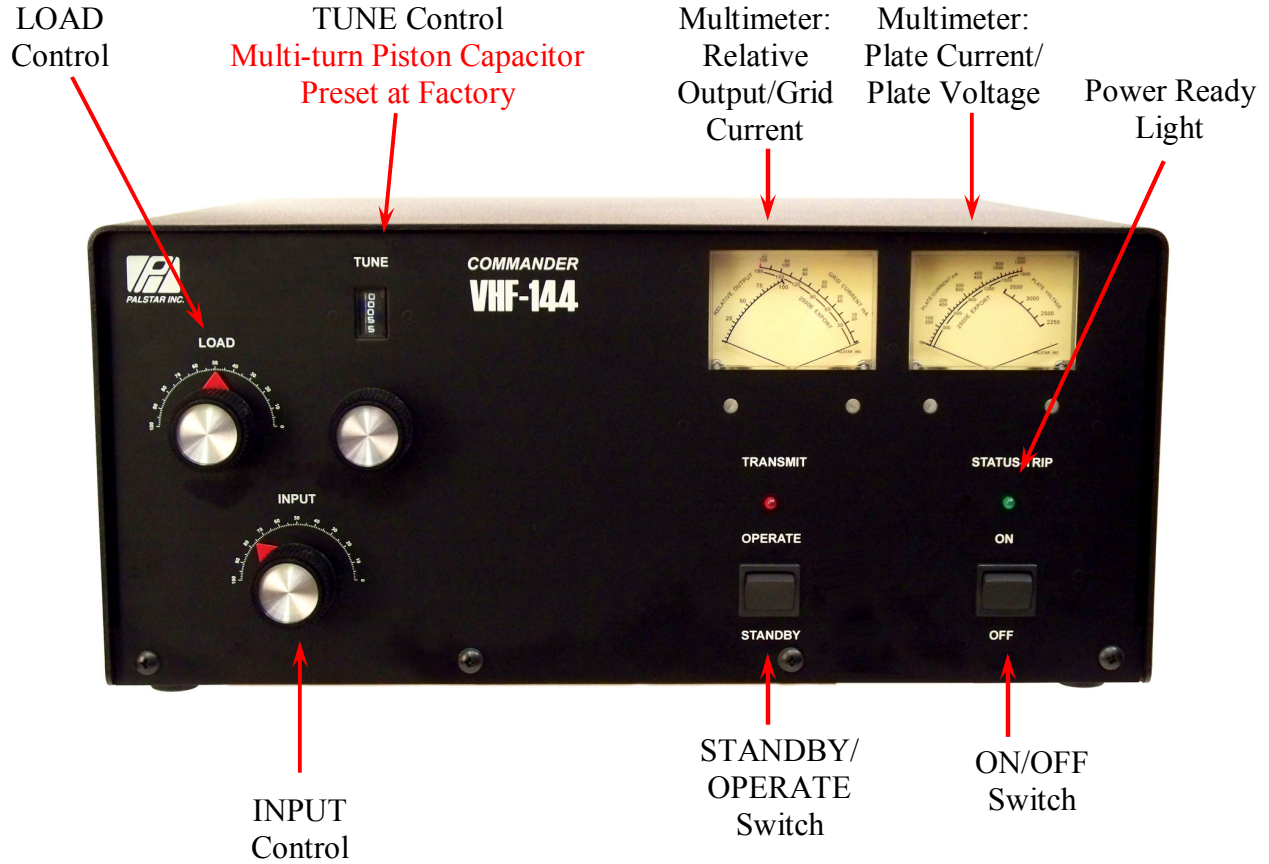

Rear Panel Layout

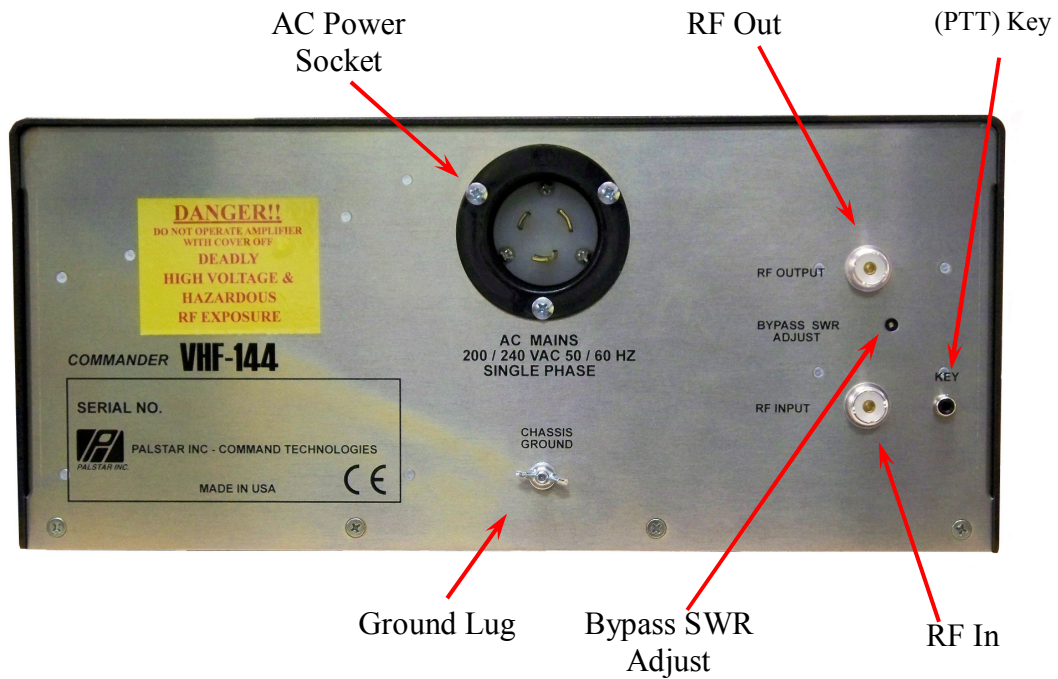

INSTALLATION PREPARATION

The Commander VHF-144 is factory wired for operation from an 234VAC line. Operation at the full rated output should not be attempted unless the AC line is capable of supplying at least 15 amps of peak current. It is strongly recommended that you operate this amplifier from a 234VAC line.

Install an appropriate plug on the end of the power cord to mate with your wall receptacle.

!!CAUTION!!

BE SURE YOU HAVE REMOVED THE LINE CORD PLUG FROM YOUR WALL SOCKET BEFORE REMOVING THE JUMPER COVER. IF YOU FAIL TO UNPLUG YOUR AMPLIFIER, YOU WILL EXPOSE YOURSELF TO LETHAL VOLTAGES.

If you change the operating voltage as described above, be sure to install the proper fuse. The fuse is a type SFE, 20 Amp for 234 VAC & 200 VAC operation.

All Commander VHF-144 amplifiers manufactured for export are wired for 200 or 234VAC, 50 or 60 Hz, depending on the final destination. No plug is supplied with the AC line cord.

Location of your Commander VHF-144 requires that no equipment be placed directly against the left side vent, as air expelled from the tube exhaust can become quite hot. Allow at least 3 inches clearance on the side of the unit and between other equipment.

To switch from transmit to receive the Commander VHF-144 requires a contact closure or keying circuit capable of sinking 15ma of positive voltage (12 VDC open circuit) to ground. This connection is made to the RCA jack on the rear panel marked KEY. Read the manual that came with your transceiver to determine the proper external connections. On some transceivers, this is not provided, and an alternate circuit will be required. Always use shielded cable for these connections.

Connect a good quality thru-line analog Wattmeter between the amplifier output jack and the antenna or dummy load using RG8 or better coax.

Connect the exciter (transceiver) RF output to the amplifier input using 50 ohm coax.

Connect a ground lead, as short as possible, from earth ground to the Commander VHF-144's rear panel ground terminal.

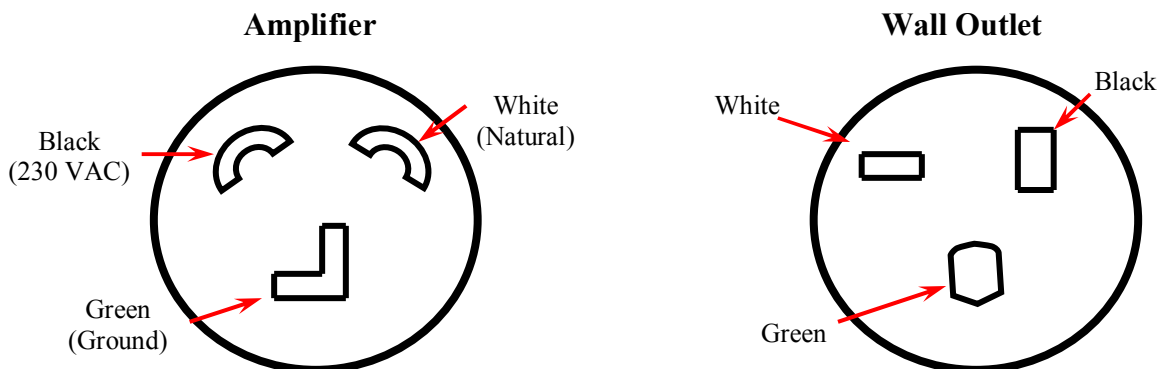

AC SOCKET CONNECTIONS

OPERATING PROCEDURE

After reading this manual and completing the Installation/Preparation Instructions, position the Commander VHF-144 front panel controls as follows:

- ON/OFF — OFF
- OPERATE/SSTANDBY — STANDBY
- INPUT — CENTER ON SCALE (50-55 on Scale)
- LOAD — MINIMUM (COUNTER-CLOCKWISE) (100 on scale is minimum capacitance)
- TUNE — LEAVE AT FACTORY SETTING (NOTE: the TUNE control is a multi-turn piston capacitor and was factory preset for operation at 144.200 MHz.)

Factory Setting Tune is 55.

After presetting these controls, switch the ON/OFF switch to the ON position. The meter lamps will illuminate, the blower will be running and plate voltage will be approximately 2800 VDC.

The 3CPX800A7 used in this amplifier requires a warm up period before RF drive may be applied, to prevent damage to the tube. A 2 minute warm up is provided by a microprocessor circuit. During warm-up the green LED will flash at 1sec rate. At the end of the warm-up period, the green POWER LED on the front panel illuminates on fully and the unit is ready for operation.

Switch the OPERATE/STANDBY switch to the OPERATE position and key the exciter with ZERO RF drive applied. The Red Transmit light should illuminate, the tube will be biased “on”, and plate idling current should be approximately 60 ma. as displayed on the Ip meter scale.

Apply a very low RF drive (less than 5 watts) and adjust the INPUT control for a peak in the plate current (Ip) on the meter. Next adjust the TUNE control for maximum output as indicated on an external Wattmeter. DO NOT adjust the LOAD control at this time. **COMPLETE THESE ADJUSTMENTS AS QUICKLY AS POSSIBLE TO AVOID STRESSING THE TUBE.**

Key the exciter in FM Mode (For Tune Procedure), and while increasing the RF drive, adjust the LOAD control clockwise in order to keep the grid current below 40ma. and to obtain a peak in output power on an external wattmeter (see chart: Typical Operating Conditions chart on the next page).

Re-peak the TUNE control for maximum output at 600ma of plate current.

The Commander VHF-144 is ready for SSB or CW on the air operation. Normal SSB operation is indicated by plate current readings on voice peaks of approximately 1/3 to 1/2 of the CW key down value.

For FM or other high duty cycle modes, limit drive to 10-15 watts maximum.

OPERATING HINTS

The Commander VHF-144 TUNE control is a high "Q" piston-type tuning capacitor with a 6:1 ratio vernier reduction drive. This control requires about 15 revolutions to tune the unit from 144 to 148 MHz.

Unless you have specified another band segment, the unit is factory tuned at 144.200, the national SSB calling frequency. If you use the Commander VHF-144 mainly for CW and SSB, and after having tuned the unit to your antenna, you will be able to QSY up or down the CW/SSB band segment without making any tuning adjustments. Unless someone changes these adjustments, it will not be necessary to retune the amplifier each time you operate it. Just turn the unit on, wait for the green light and begin transmitting.

If you decide later to operate in the FM portion of the band, it is best done by tracking up the band about 500 KHz at a time. To do this, key the exciter with low drive (5 watts or less), re-tune INPUT for a peak in plate current (Ip), and readjust TUNE control for maximum output, repeating this procedure as you move up the band. This is also useful if you happen to forget where you left it tuned.

TYPICAL OPERATING CONDITIONS

DRIVE	GRID CURENT	PLATE CURENT	POWER OUTPUT
12.5 Watts	15 ma	400 ma	450 Watts
18.5 Watts	25 ma	500 ma	650 Watts
30 Watts	35 ma	600 ma	1000 Watts

Limited Warranty

Palstar Inc. warrants the Commander VHF-144 to be free from defects in material and workmanship under normal use and service **for a period of one (1) year from the date of delivery to the first buyer** (the “Warranty Period”). Palstar Inc.’s obligation under this warranty is limited to repair or replacement of the product at its option at the Palstar factory in Piqua, OH.

This warranty is effective only when the product is returned to the factory with all transportation charges prepaid and examination of the product discloses, in Palstar’s judgment, to have been defective during the Warranty Period.

The Warranty Period shall not extend beyond its original term with respect to interim in-warranty repairs by Palstar. This Warranty Period shall not apply to any product which has been repaired or altered by anyone other than Palstar without prior written authorization. Warranty does not extend to any products which have been subject to damage from improper installation, application or maintenance in accordance with the operating specifications. Palstar neither assumes nor authorizes any person to assume for it any obligation or liability other than herein stated.

Shipping Your Amplifier Back to the Factory

Due to the necessity of shipping the amplifier with the HV transformer removed, please contact the factory for instructions before sending an amplifier back to us. There are circumstances in which it may not be necessary to return the HV transformer, thereby saving you shipping charges. When you call, Palstar will inform if transformer return is necessary. If transformer return is necessary, remove it from the amplifier cabinet and ship it separately, preferably in its original crate.

Repair Policy

When sending in a product for service, see the section above. If not using the original packing materials, please “double” box it carefully and ship it insured for your protection. Please include a note clearly describing the problem, how you wish the item returned and how you wish to pay for the service. Package your unit properly. Palstar, Inc. is not responsible for merchandise damaged in shipment. Our service rate is \$30 per hour (1/2 hr. minimum).

Return Policy

All returns must receive prior authorization from Palstar. Returned items must be received in original—AS SHIPPED—condition including the original box, manuals, accessories, and copy of sales receipt. Returns must be within 14 days of purchase. Returned items are subject to a 20% restocking fee. Shipping is not refundable.

Commander VHF-144 HV Power Supply

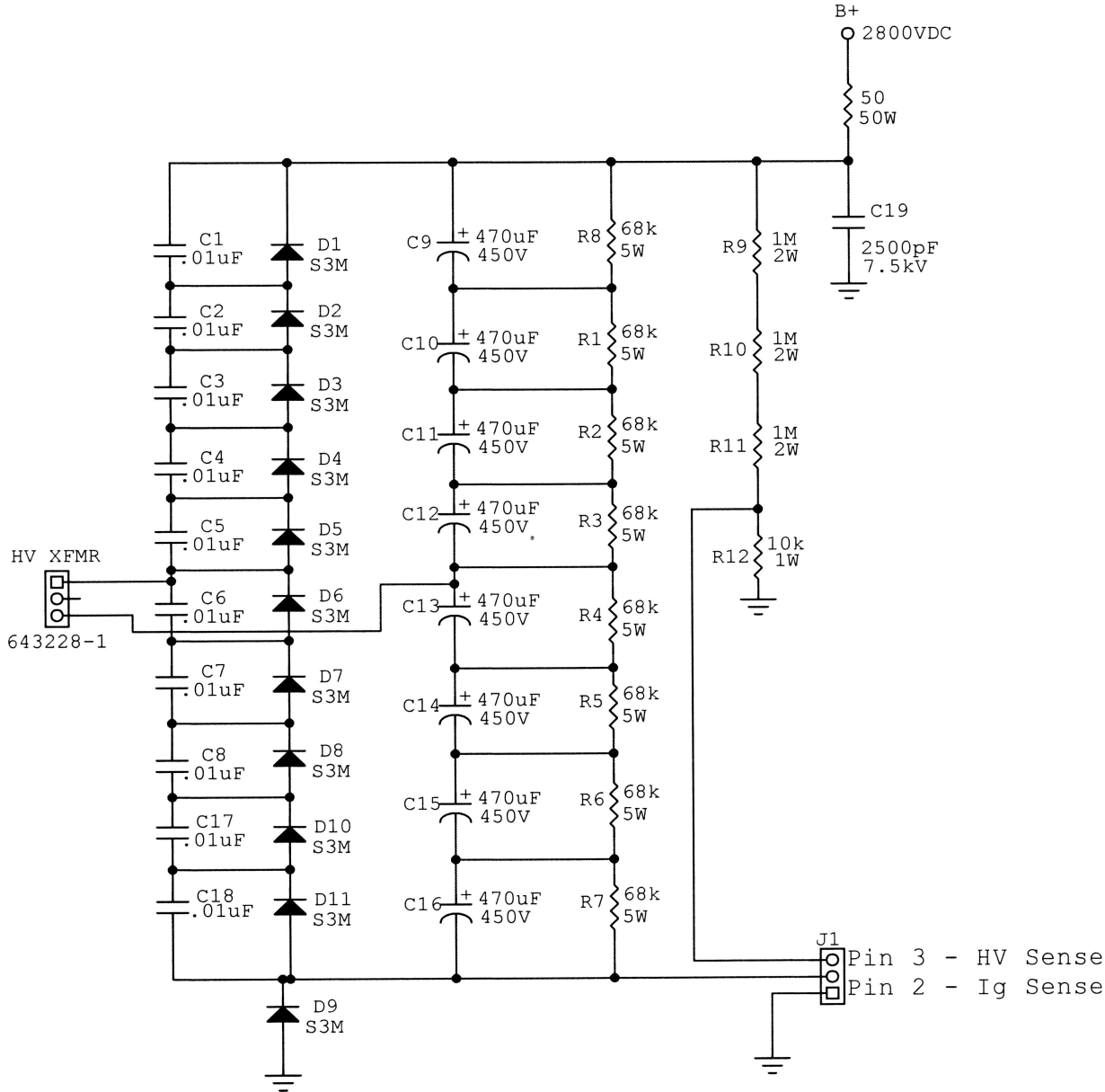

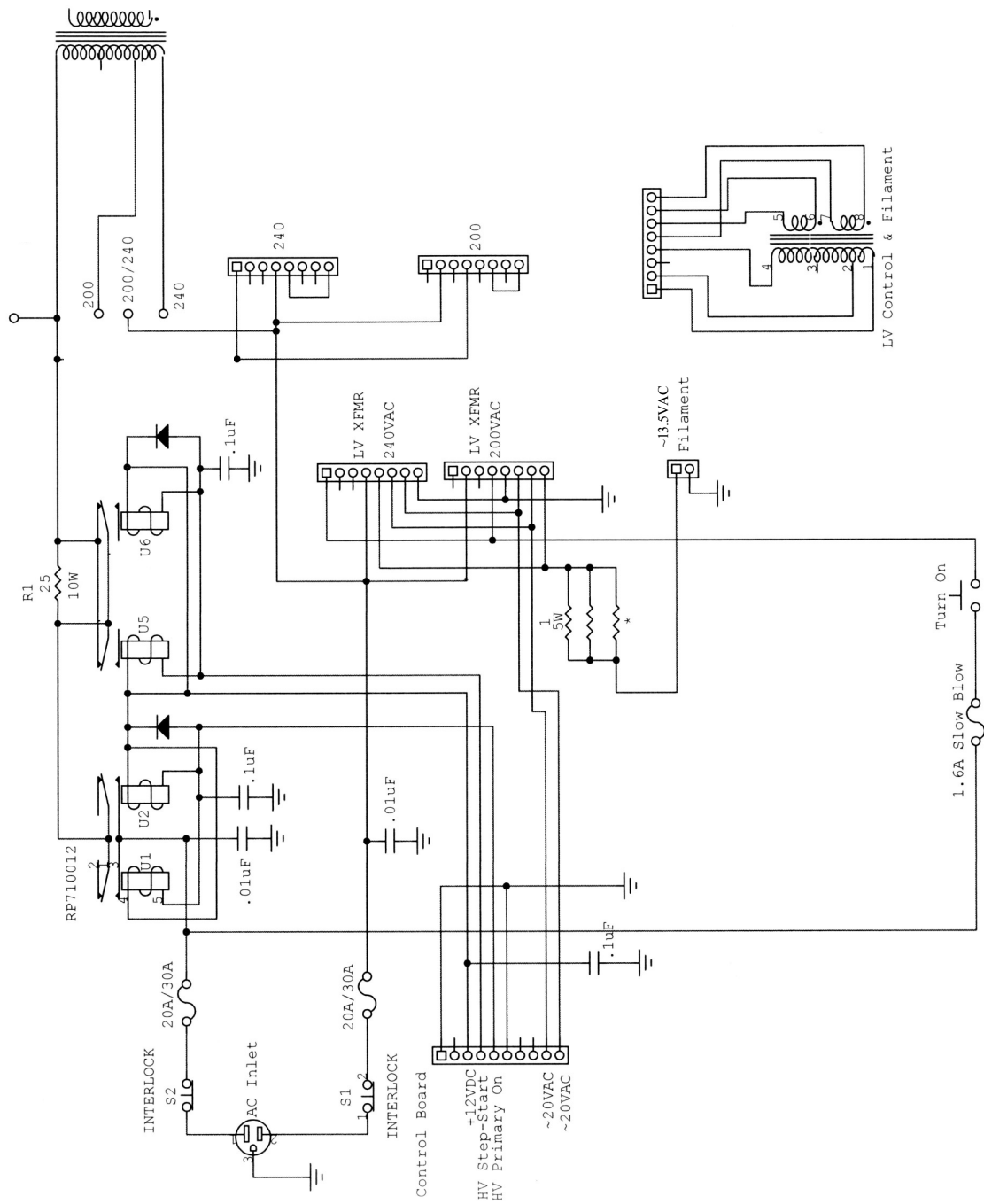

AC Mains and Step-Start Board (VHF-144)

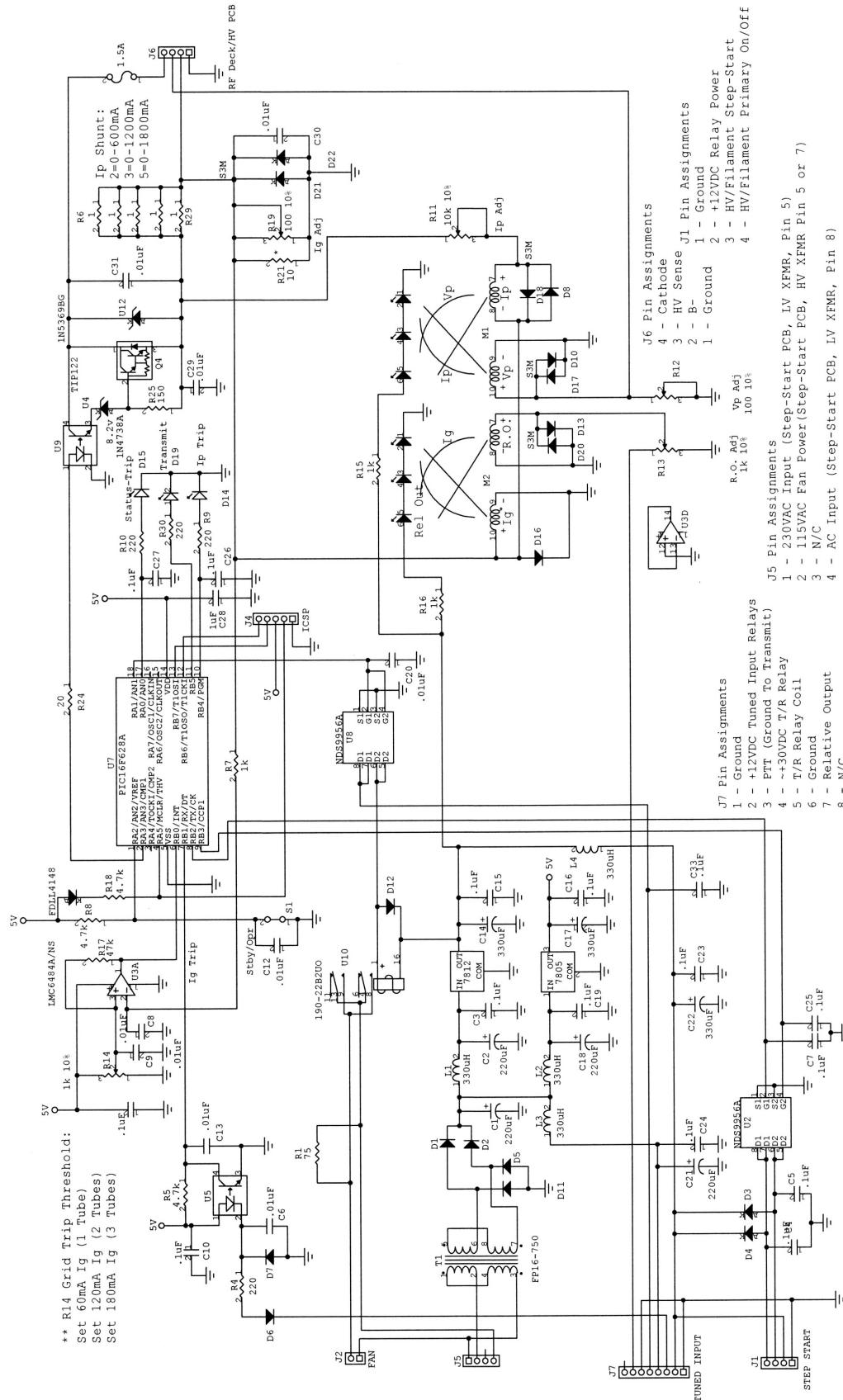

Control and Metering Board VHF-14

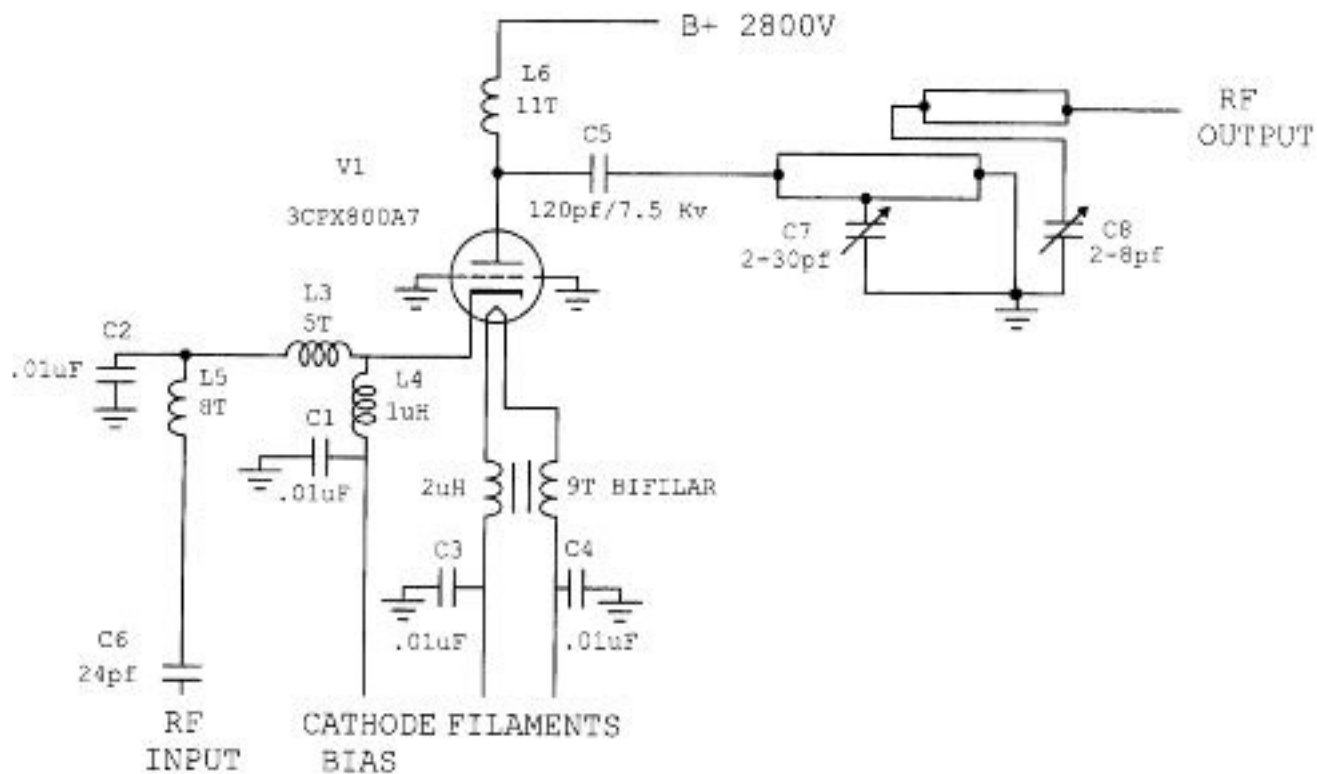

RF Deck VHF-144

Commander VHF-144 T/R Relay Board

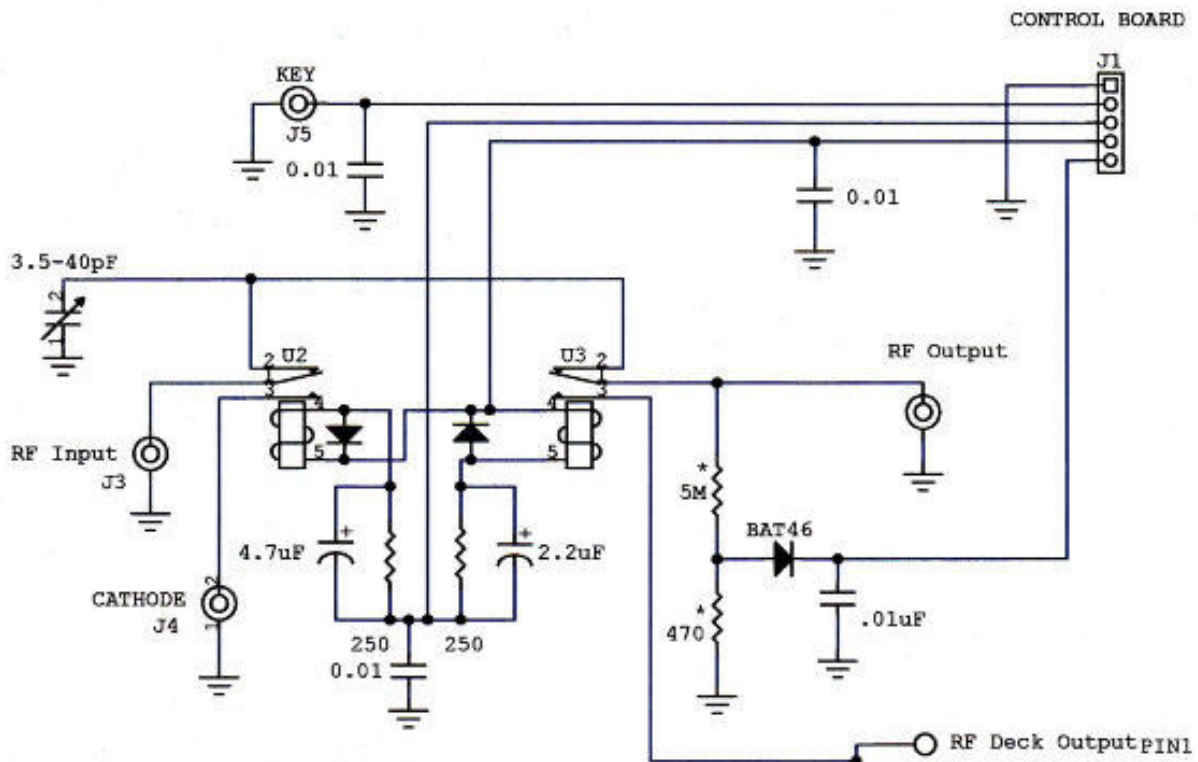

- J1 Pinout
- 1 Ground
 - 2 PTT (Active Low)
 - 3 Relay Control
 - 4 Relay Pwr ~20VDC
 - 5 Relative Output

- RF Deck Output PIN1
- STUB PIN2
- STUB GND PIN3

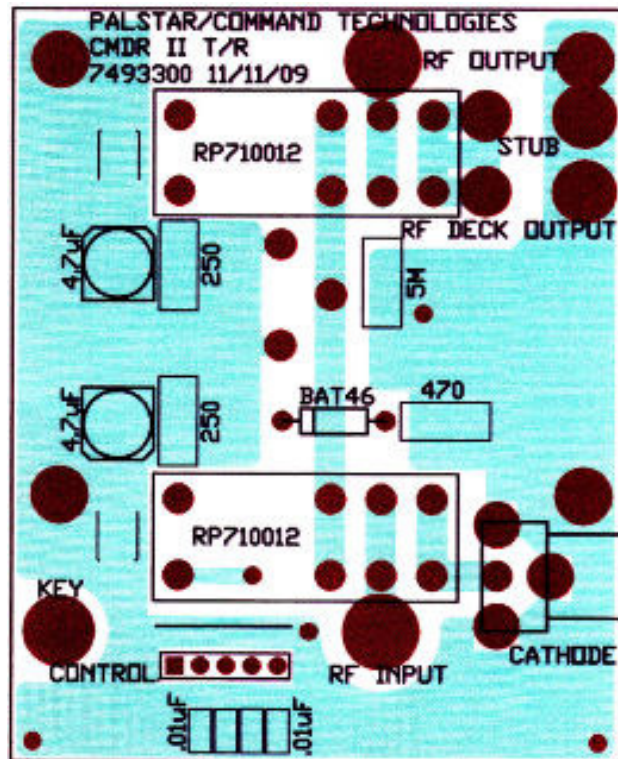

Commander VHF-144 Voltage Doubler Power Supply Board

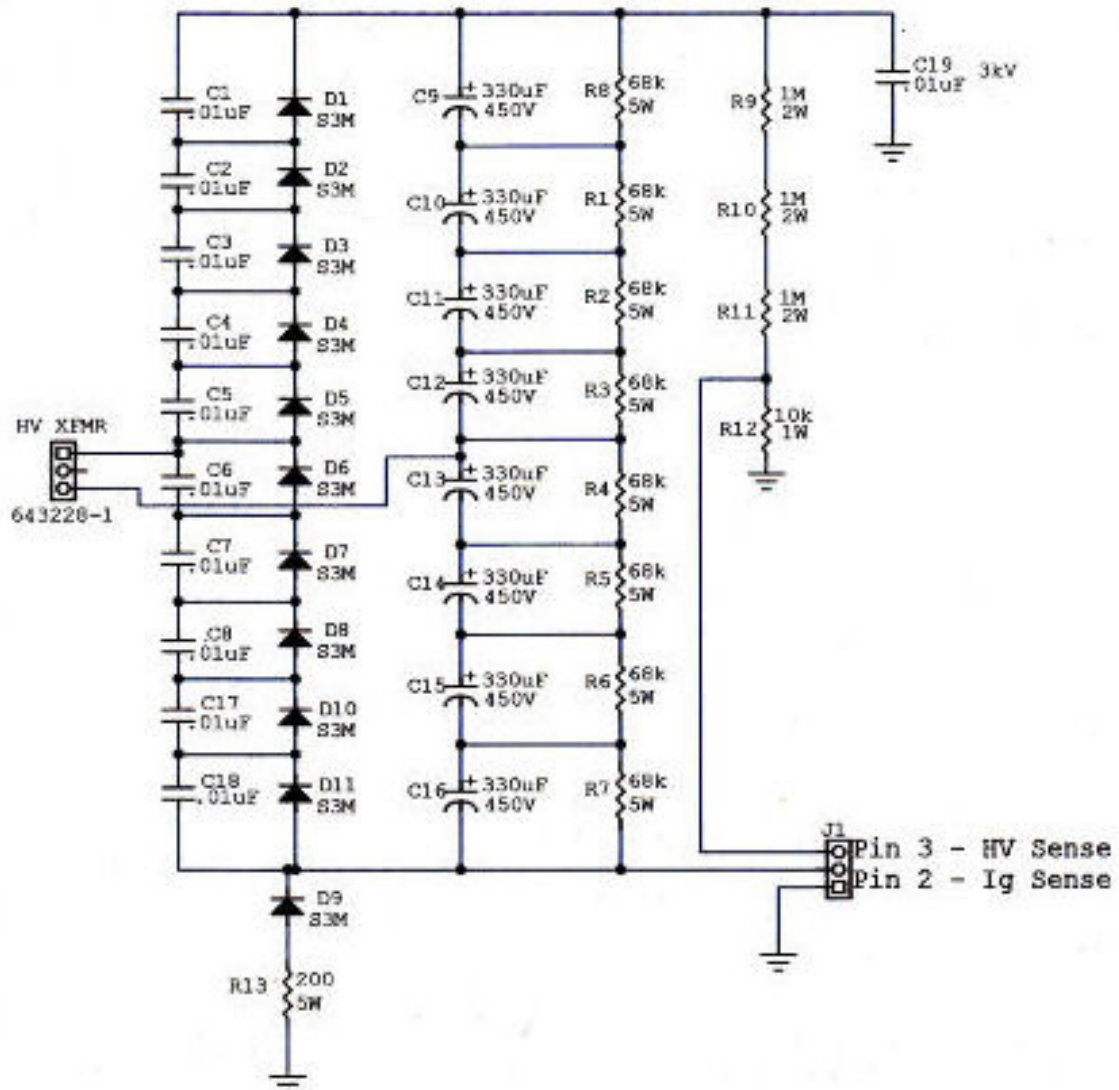

RF Deck

3CPX800A7
Triode Tube

RF Plate Choke

Plate
Capacitor
120pf/7.7kv



Load Tuning
Capacitor

Input Tuning
Piston Capacitor

Dual Meters

Grid Current:		Scale
0-60ma	Single Tube	Top
0-120ma	Two Tubes	Mid
0-180ma	Three Tubes	Bottom

Grid Current:		Scale
0-600ma	Single Tube	Top
0-1200ma	Two Tubes	Mid
0-1800ma	Three Tubes	Bottom

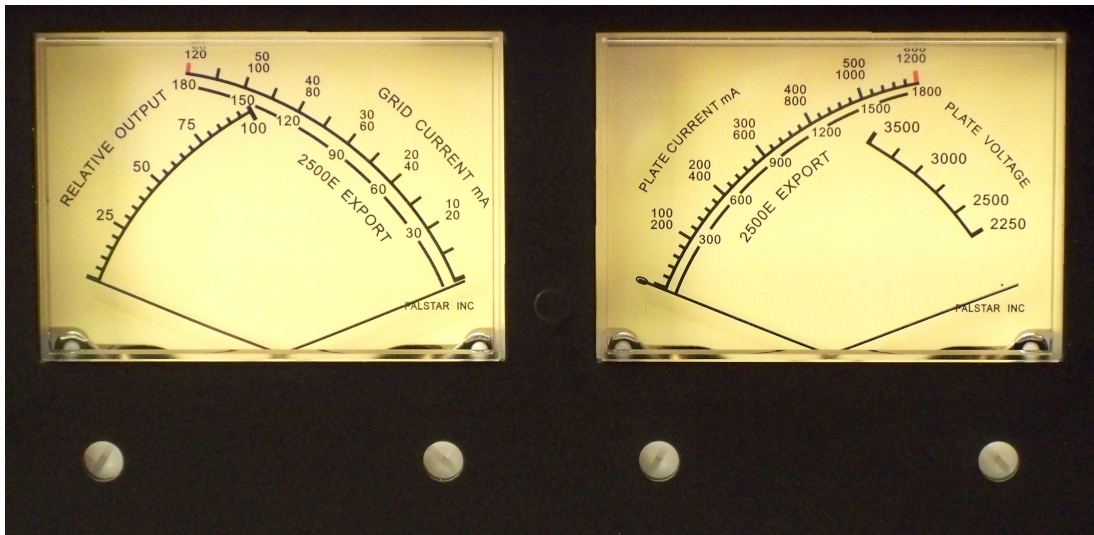

Meter Board

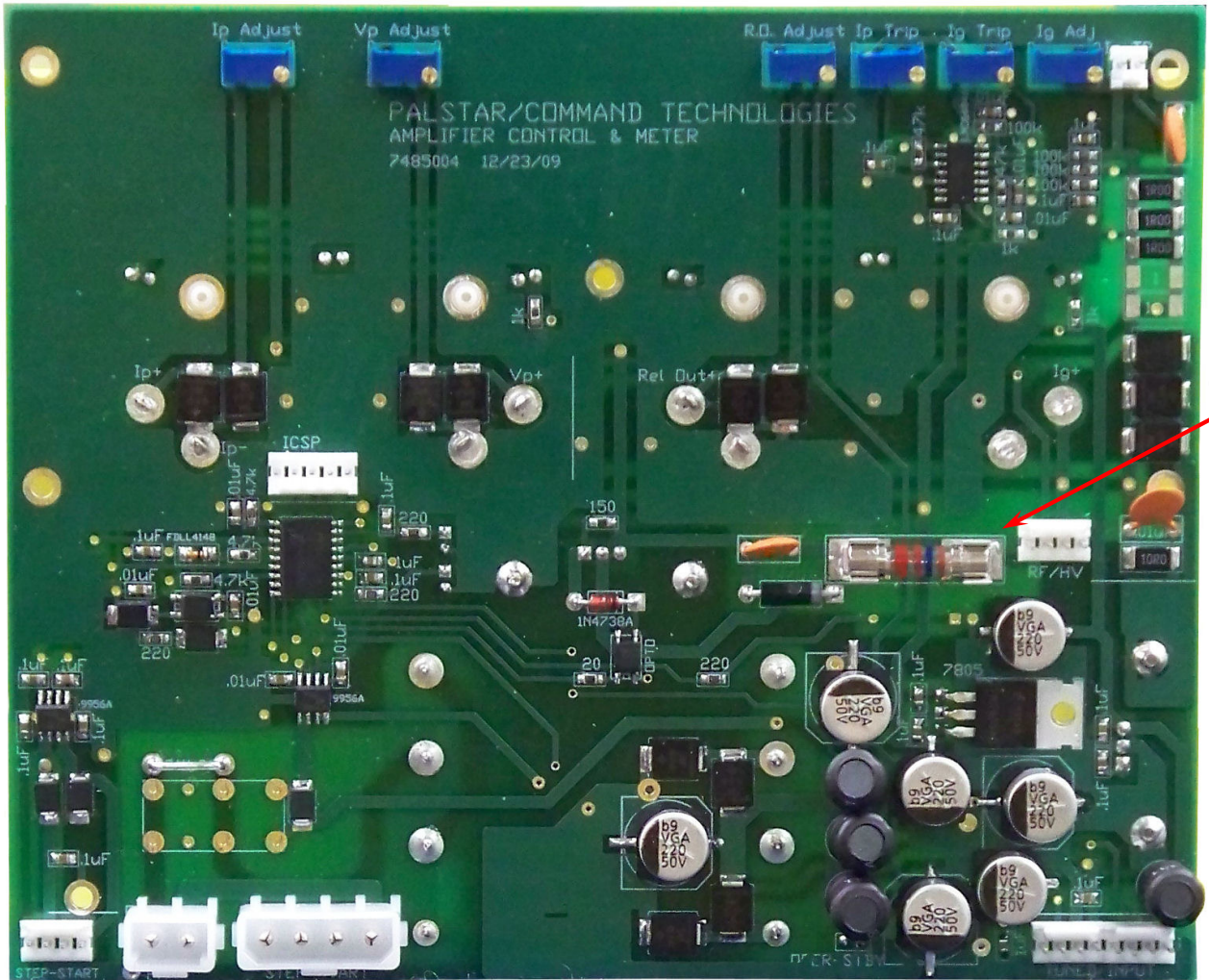

Cathode Fuse

Step-Start Board

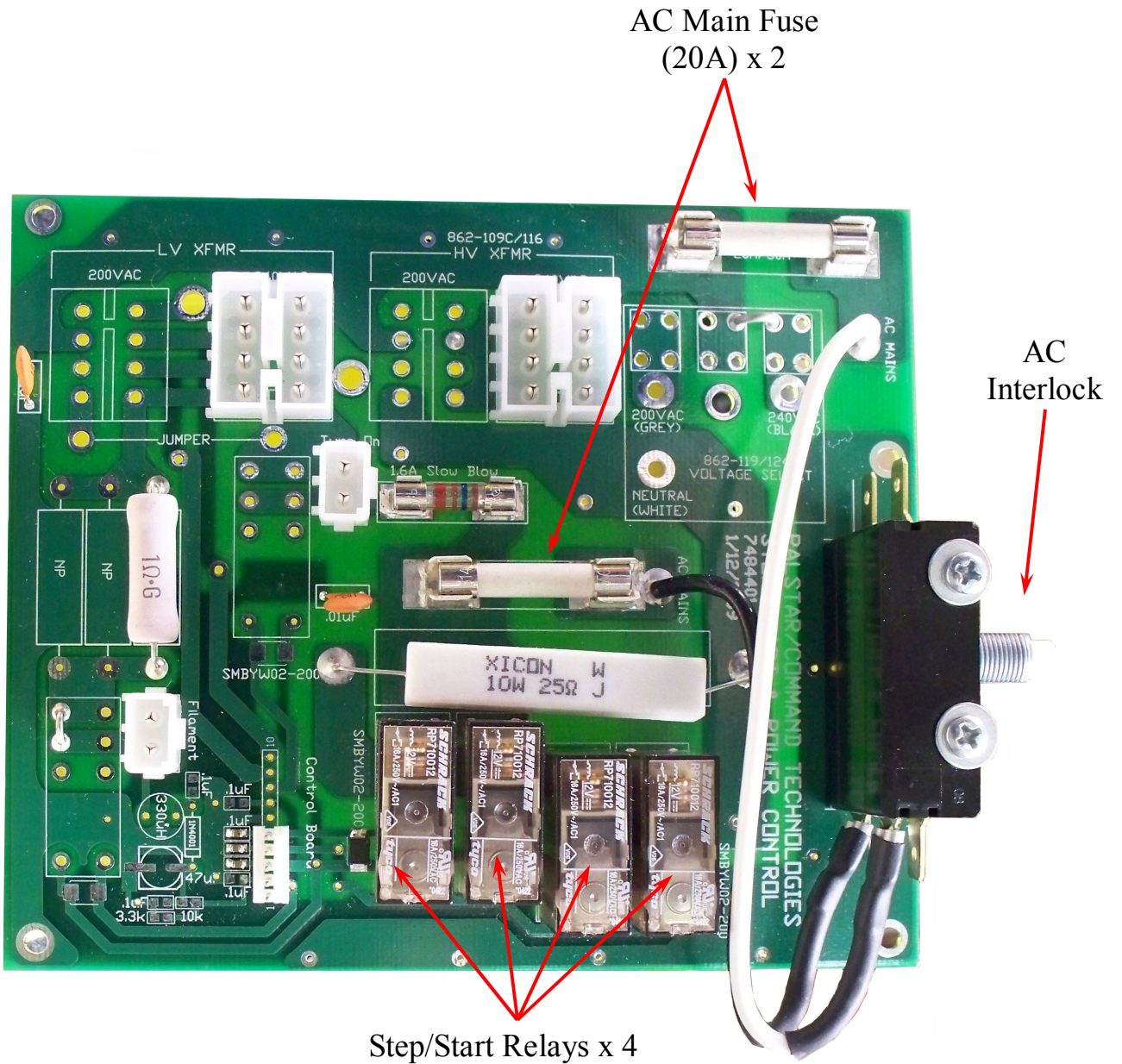

Power Supply

470uF Capacitor
450 vdc x 8

RF Output

HV Sense

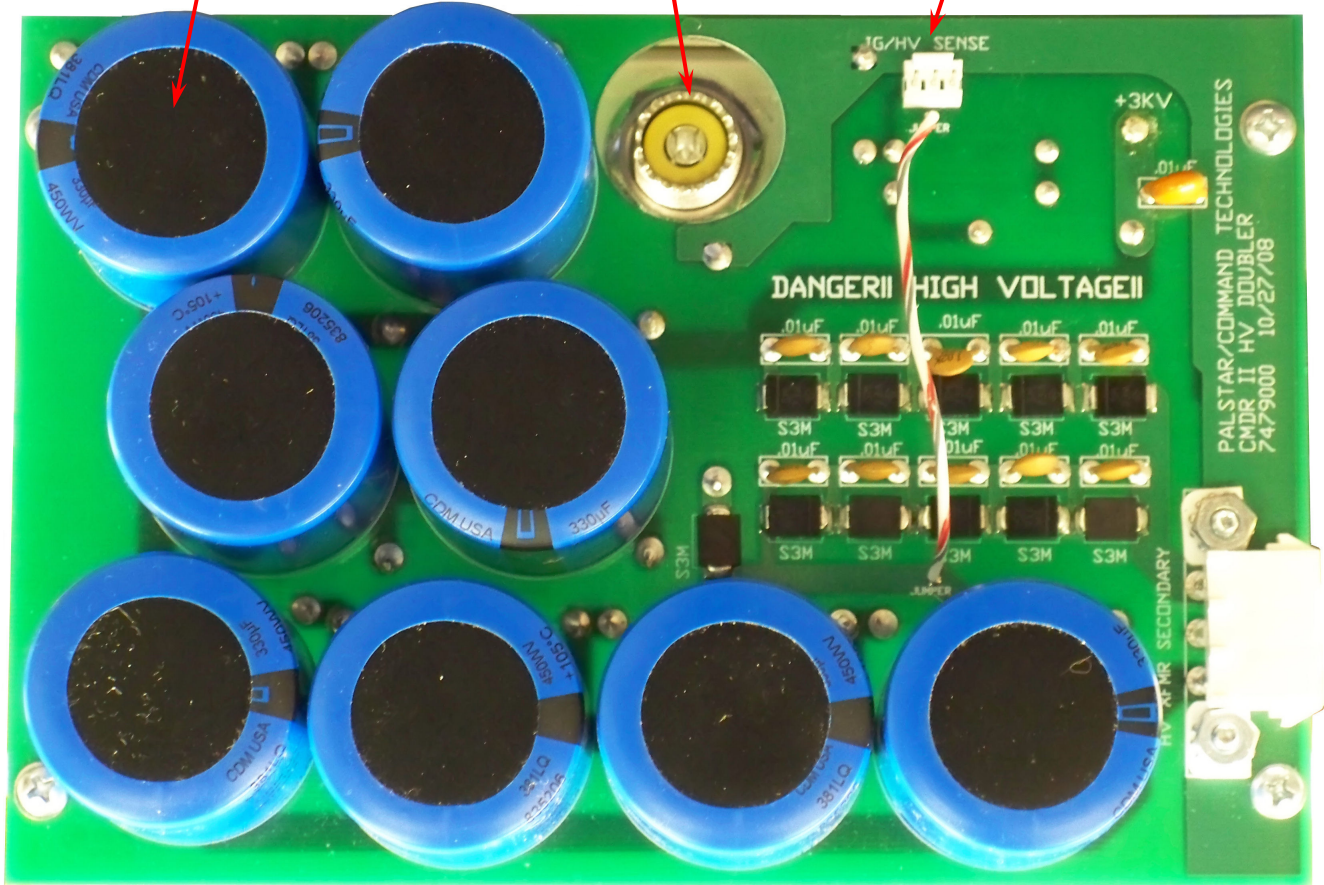



Palstar Incorporated

9676 N. Looney Rd.,
Piqua, OH 45356 USA

Customer Service and Sales Telephone:

1-800-773-7931

Fax:

1-937-773-8003

Email:

info@palstar.com